

Top View

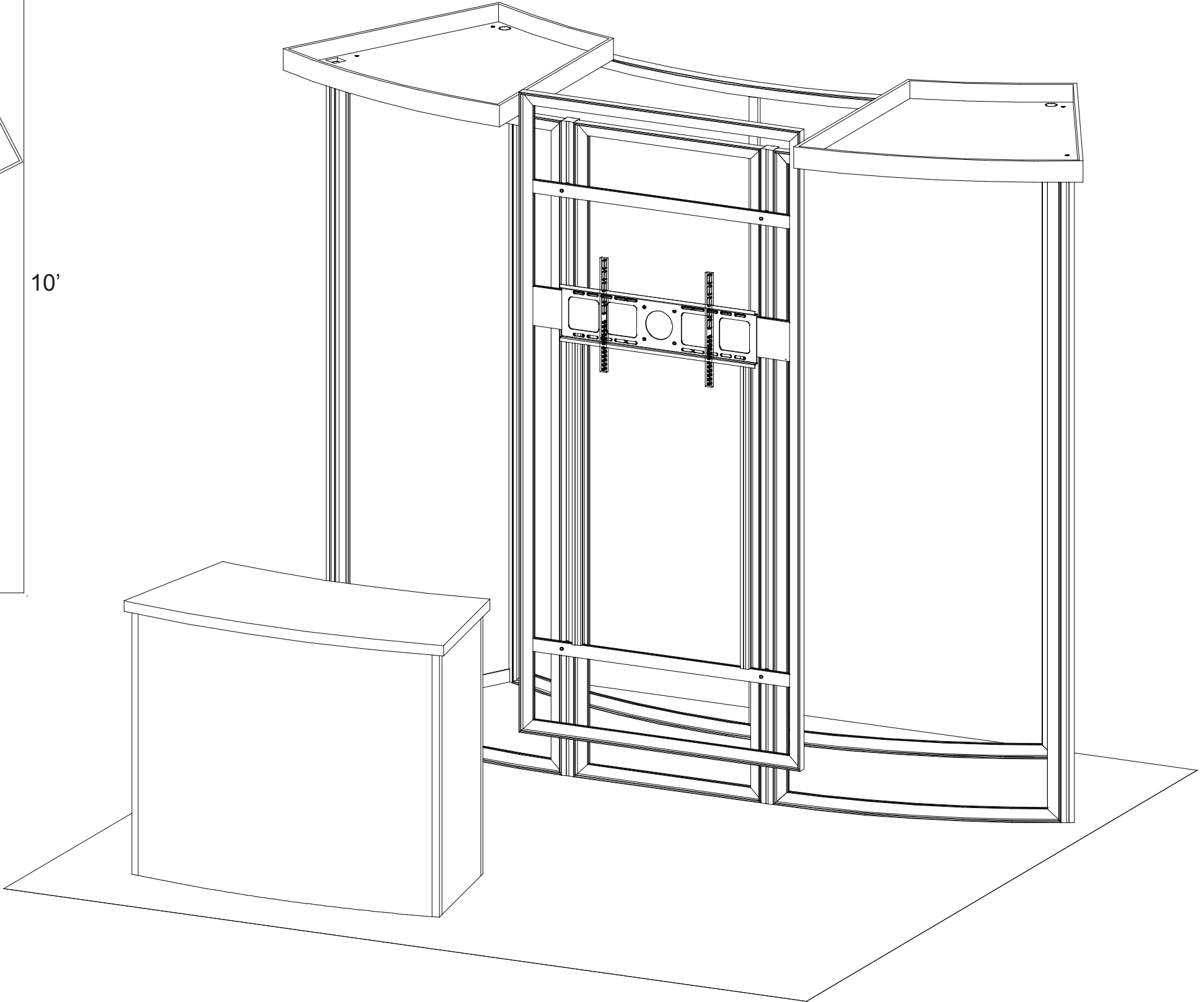

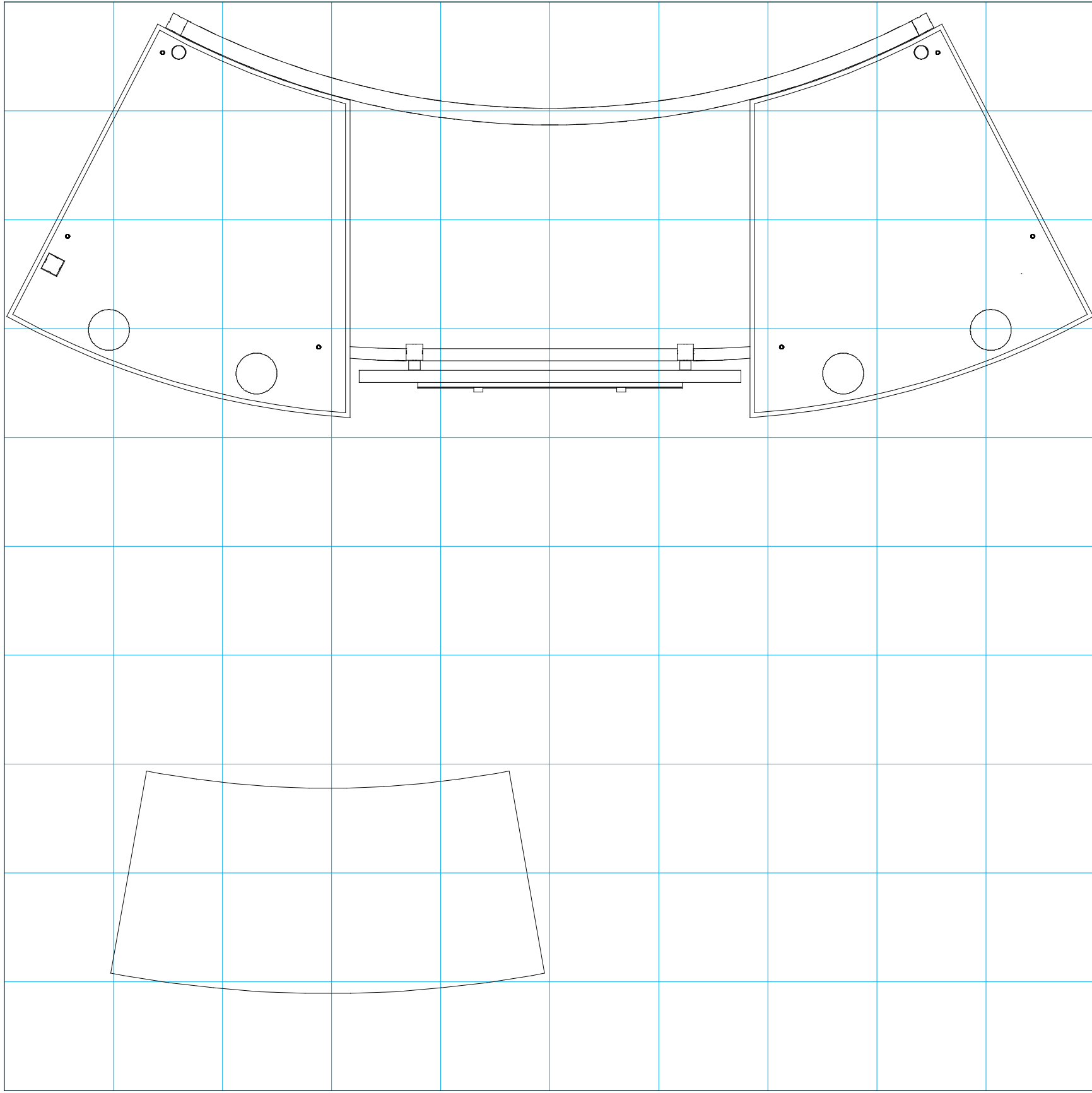
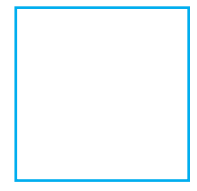

 = 1 sq foot

# euro lt | HYBRIDS

## Using Your Setup Instructions

The Euro LT Hybrids Setup Instructions are created specifically for your configuration. They are laid out sequentially in levels, including exploded views, and a logical series of detailed steps to assemble the main structure and components. We encourage you to study the instructions **before** attempting to assemble your exhibit.

Each page reminds you to tighten the setscrews after disassembling your exhibit to prevent loss of the locks and setscrews (see below in RED). This is VERY IMPORTANT.

## Cleaning and Packing Your Display

- 1) Use care when cleaning aluminum extrusion or acrylic inserts. Use only non-abrasive cleaners.
- 2) When cleaning laminate inserts, countertops, or panels use mild cleansers and a soft material such as cotton.
- 3) Keep all display components away from extreme heat and long exposure to sunlight to avoid warping and fading.
- 4) Retain all packing material. It will make re-packing much easier and will reduce the likelihood of shipping damage.

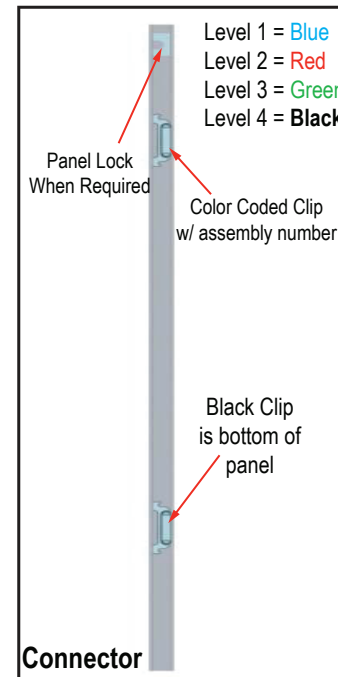

Each component has 2 clips, the lower clip is ALWAYS black. The top clip is color coded to distinguish which level. The color coded clip also contains the numbered label.

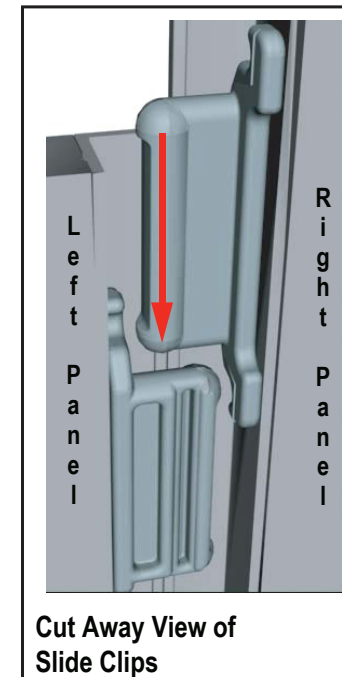

Components connect together by aligning them and sliding downward connecting clips together.

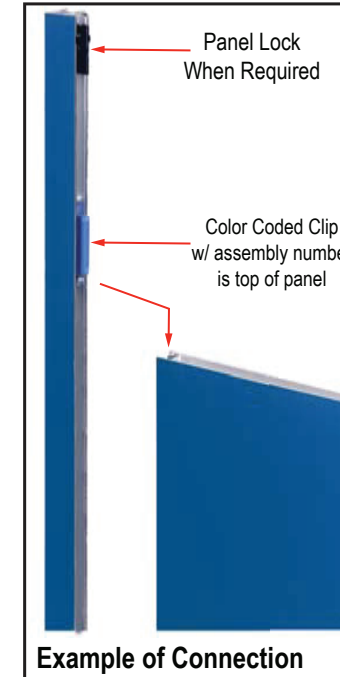

Configurations are assembled from left to right, usually starting with #1 and following the numbered sequence.

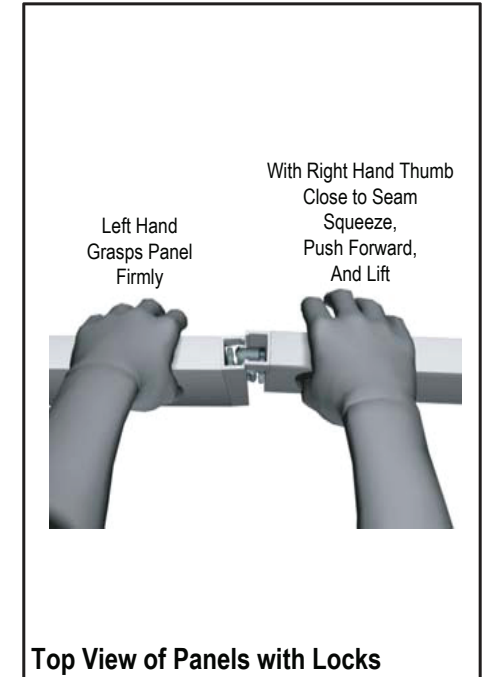

The first level of components contain panel locks that are located at the top of the panel for extra stability and seamless connection. When disassembling panels twist top connection slightly and lift right panel upward.

## General Setup Instructions for Extrusion System



Most exhibits can be assembled with the supplied Hex Key Tool. Occasionally, a flat head screwdriver may be required.



Most horizontal extrusion connections have a patented expandable lock. This lock inserts into the groove of an opposing extrusion. Tightening the lock with the Hex Key Tool expands the lock and creates a strong positive connection.

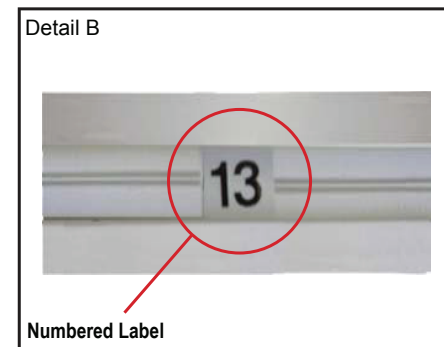

Each extrusion contains a numbered label which corresponds with setup instructions. The label is located within a groove of the extrusion (when possible). With extrusion components the labels contain Black numbers unless otherwise specified.



Remove only (1) setscrew when disassembling. Replace setscrew in extrusion after assembling it. Before packing, replace setscrew in extrusion to avoid losing it.

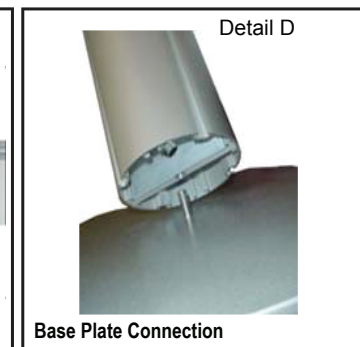

Attach base plate to round or square vertical extrusion using the bolt provided. Be careful not to strip the threads.

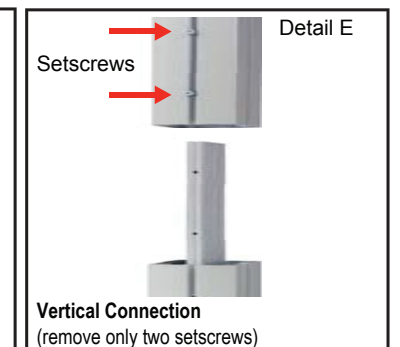

When vertical extrusions are packed in portable cases rather than crates or tubs, they must be broken down into smaller sections which then require assembly.

Remove only (2) setscrews when disassembling. Replace setscrews in extrusion after assembling it. Before packing, replace setscrews in extrusion to avoid losing them.

- 1) Locate channels along the edges of extrusions
- 2) Insert graphic corners first into channels then center point of graphic into channels. Allows for proportional fit around the perimeter of the extrusion.
- 3) Working from center to corner, slide silicon edge on graphic into channel.
- 4) After all edges of graphic have been inserted into channels, step back and assess graphic fit, make adjustments where needed.

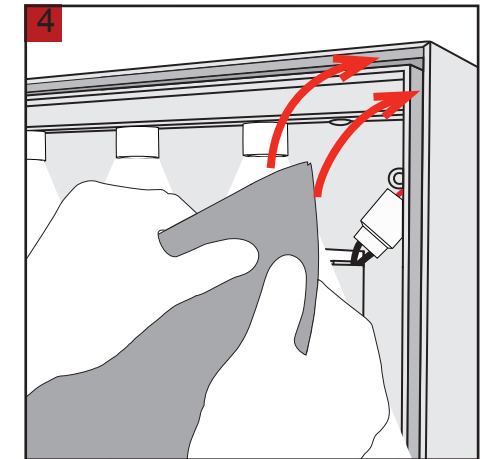
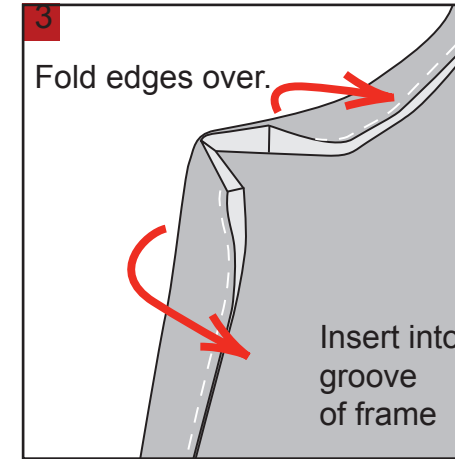
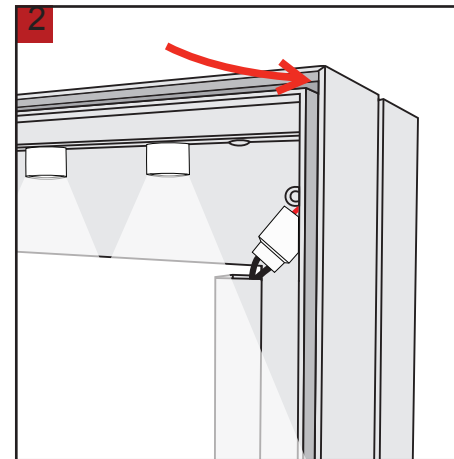
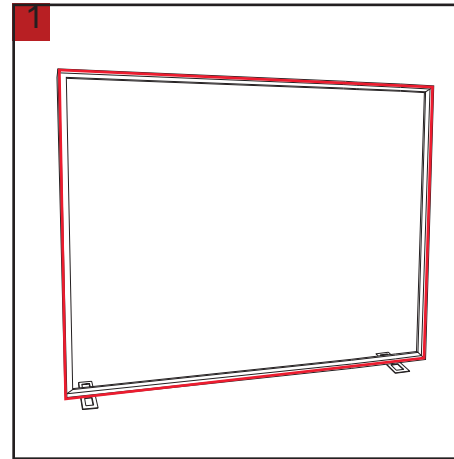



Item	Qty.	Description
1	1	92" S44 Vertical Extrusion
1A	1	92" TSP49 Vertical Extrusion
2	1	92" S44 Vertical Extrusion
2A	1	92" TSP46 Vertical Extrusion
3	1	92" S44 Vertical Extrusion
3A,3B	1,1	92" TSP46 Vertical Extrusion
4	1	92" S44 Vertical Extrusion
4A,4B	1,1	92" TSP46 Vertical Extrusion
5	1	92" S44 Vertical Extrusion
5A	1	92" TSP46 Vertical Extrusion
6	1	92" S44 Vertical Extrusion
6A	1	92" TSP49 Vertical Extrusion
8,8A	1,1	28" TSP46 curved Horizontal Extrusion
9,9A	1,1	40" TSP46 curved Horizontal Extrusion
10,10A	1,1	28" TSP46 curved Horizontal Extrusion
12,12A	1,1	84.4392" TSP49 curved Horizontal Extrusion

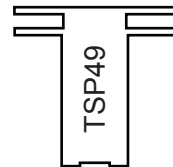
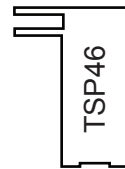

Steps:

Assemble frames flat on floor, then raise upright to attach connecting extrusions.

Front Frames:

- 1) Assemble horizontals [8] [8A] between verticals [2A] [3A], then connect horizontals [9] [9A] between verticals [3B] [4A], and attach horizontals [10] [10A] between verticals [4B] [5A]. See [TSP46 Corner Connection](#) detail.
- 2) Attach vertical [2] to vertical [2A], using cam locks. See [Custom Cam Lock for TSP46](#) detail.
- 3) Attach vertical [3] between [3A] and [3B], using cam locks.
- 4) Attach vertical [4] between [4A] and [4B], using cam locks.
- 5) Attach vertical [5] to vertical [5A], using cam locks.

Back Frame:

- 6) Connect horizontals [12] [12A] between verticals [1A] [6A]. See [TSP49 Corner Connection](#) detail.
- 7) Attach frame assembly [8/8A/2A/3A] between verticals [2,3], using cam locks. See [Custom Cam Lock for TSP49](#) detail.

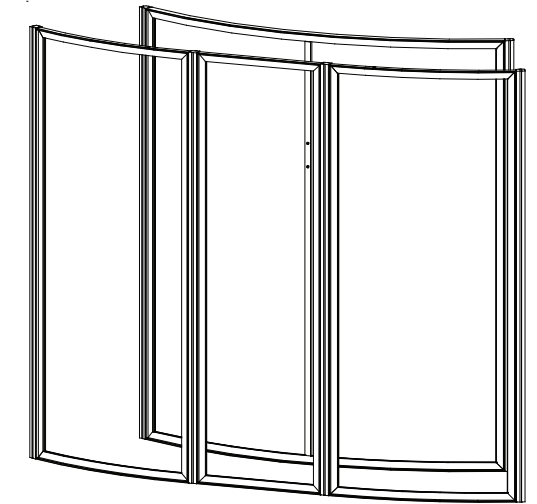

Completed Frames Assembly

\* TSP46 Corner Connection

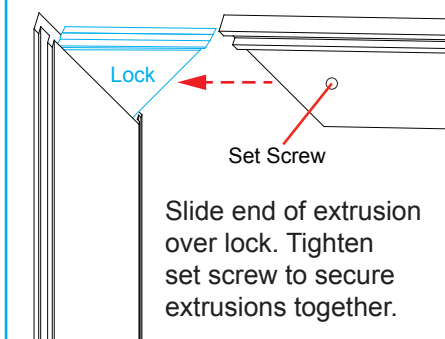

\* TSP49 Corner Connection

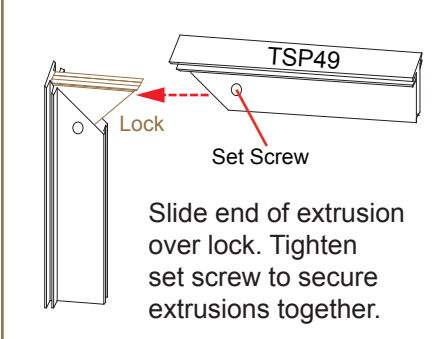

\* Custom Cam Lock for TSP46

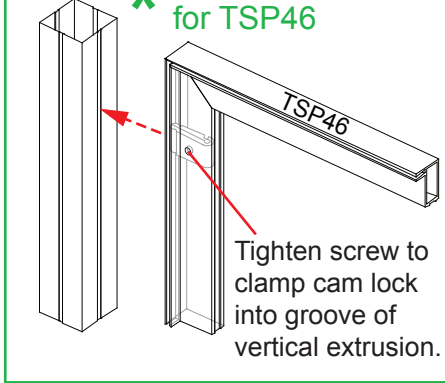

\* Custom Cam Lock for TSP49

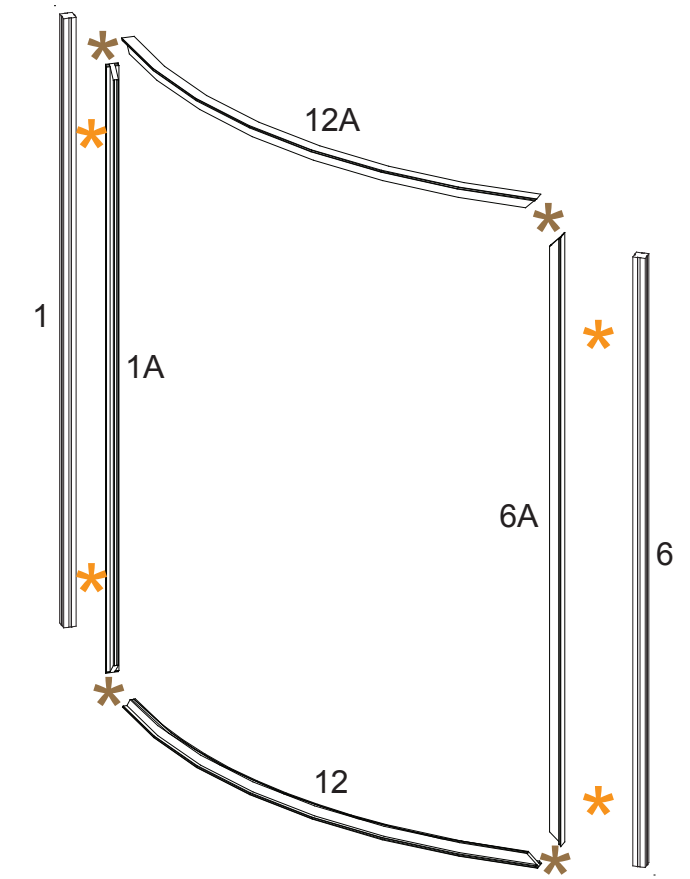
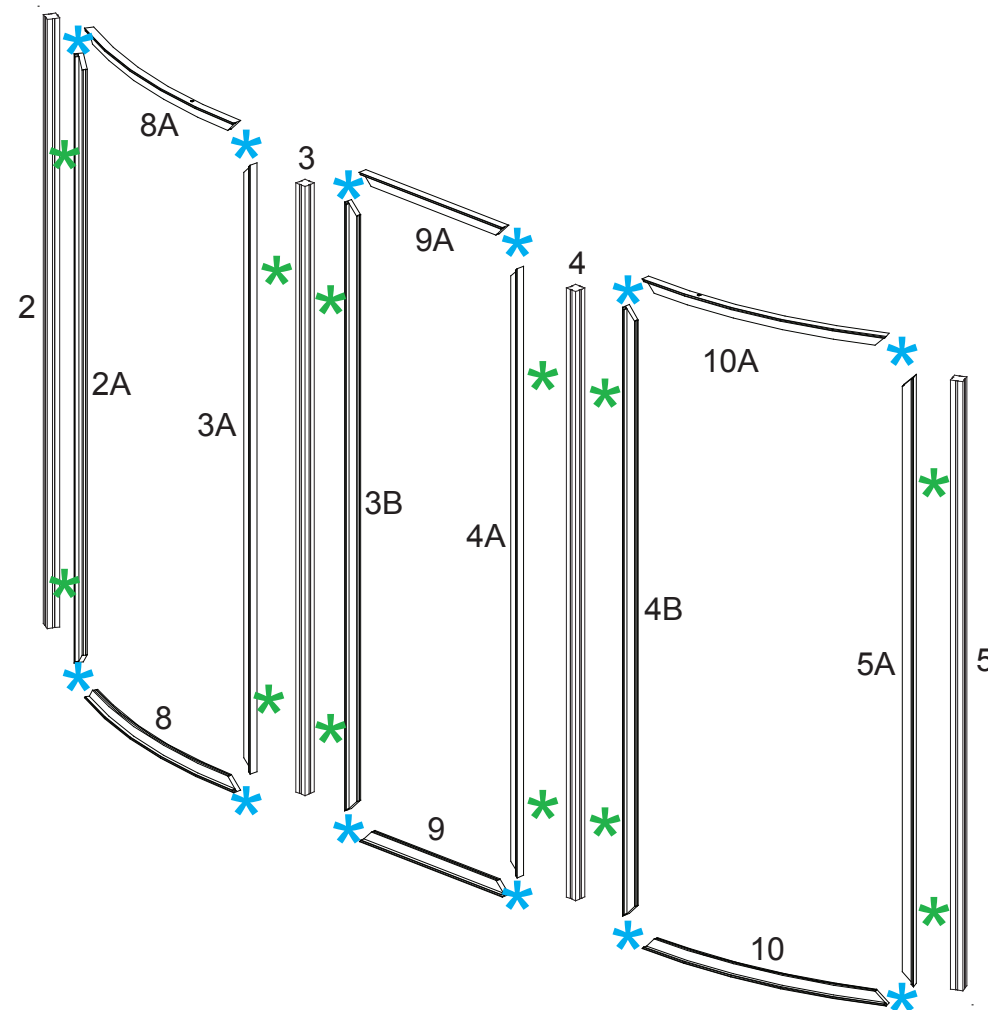
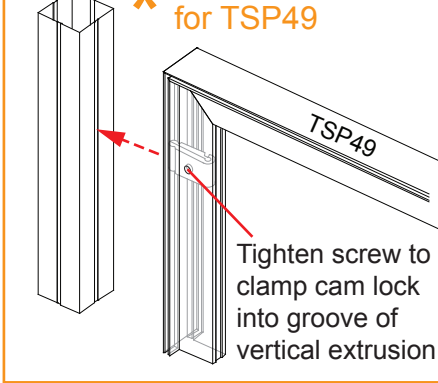

Item	Qty.	Description
7,7A	1,1	28" Z45 Horizontal Extrusion
11,11A	1,1	28" Z45 Horizontal Extrusion
13	1	88.417" Z33 Vertical Extrusion
--	1	Door Threshold
--	2	Infill

Steps:

- 8) Attach horizontal [7] between vertical [1] and [2], then slide **Infill** between verticals then secure with upper horizontal [7A].
- 9) Install door threshold between verticals [5] and [6].  
See **Door Threshold Attachment** detail.
- 10) Connect horizontal [11] between verticals [5] and [6], then slide **Infill** between verticals then secure with upper horizontal [11A].
- 11) Attach vertical [13] between horizontals [12] and [12A].
- 12) Connect door between verticals [5] and [6].  
See **Door Connection** detail.
- 13) Apply SEG graphics to front and back of closet assembly.  
See SEG Graphic Installation sheet for instruction.

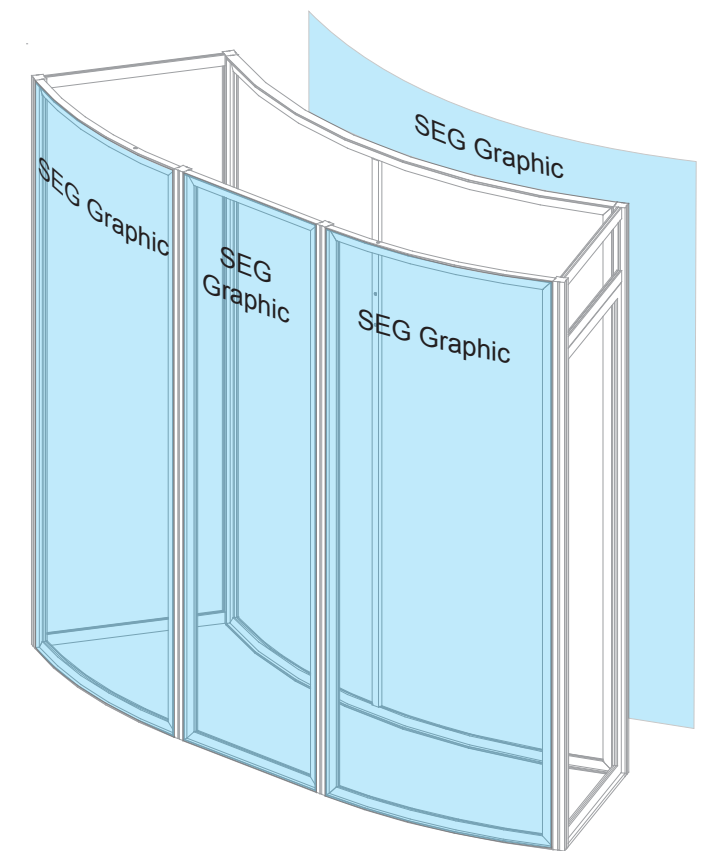
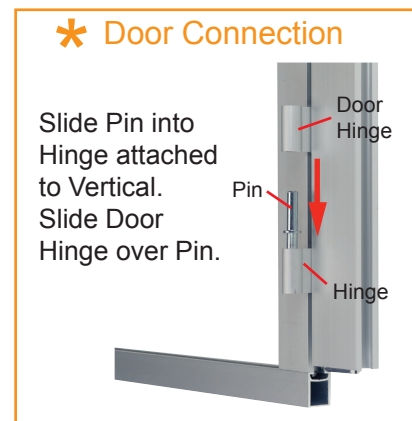
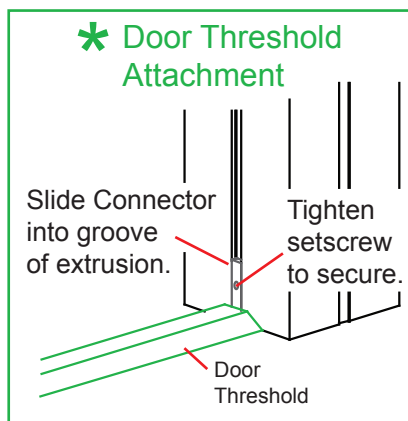
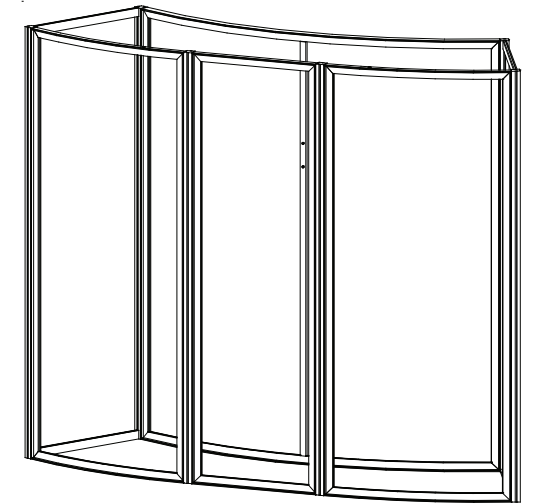
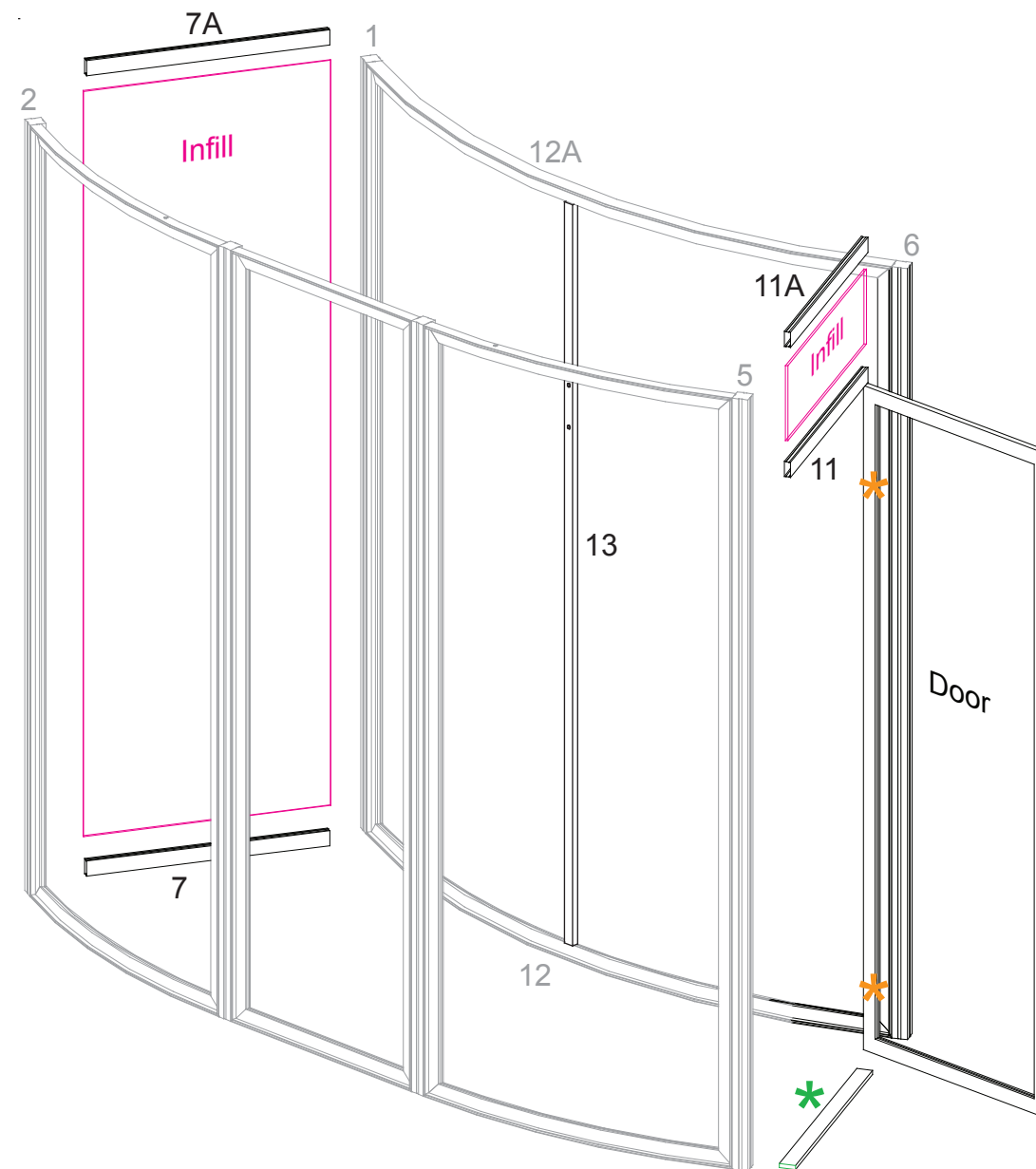

Item	Qty.	Description
14,14A	1,1	42" TSP46 Horizontal Extrusion
15,15A	1,1	90" TSP46 Vertical Extrusion
16,16A	1,1	38.417" Z45 Horizontal Extrusion
17	1	38.417" Z140 Horizontal Extrusion
18	2	44" S40 Vertical Extrusion

Steps:

- 1) Connect horizontals [14,14A] between verticals [15,15A]. See [TSP46 Corner Connection](#) detail.
- 2) Attach horizontals [16] [16A] and [17] between verticals [15] and [15A], with verticals [18] between horizontals [16] and [17].
- 3) Attach assembled frame to closet verticals [3] and [4], using standoffs.
- 4) Attach monitor mount to horizontal [17]. See [Monitor Mount Attachment](#) detail.
- 5) Install SEG graphic to front of frame. See SEG Graphic Installation sheet for instruction.

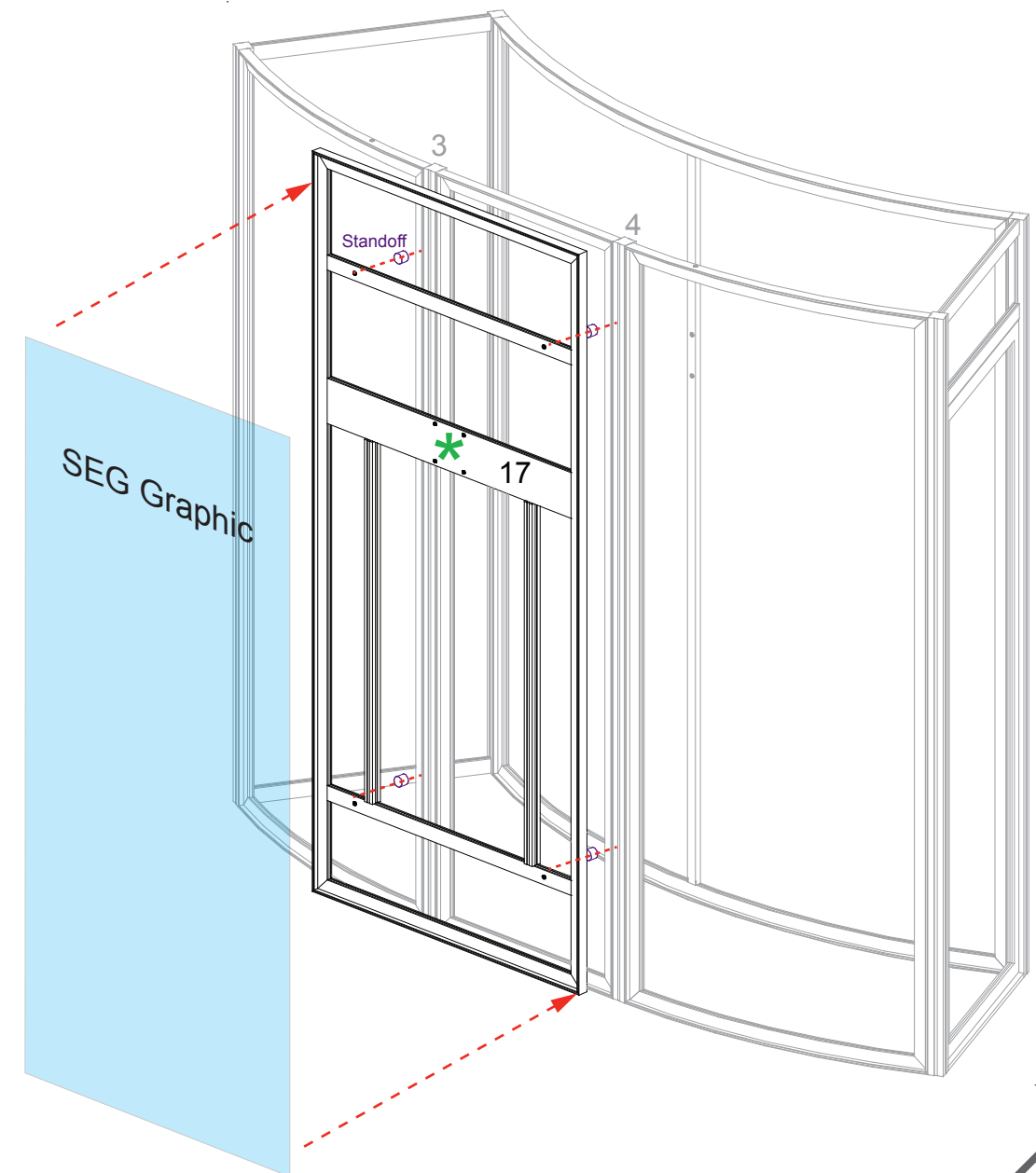
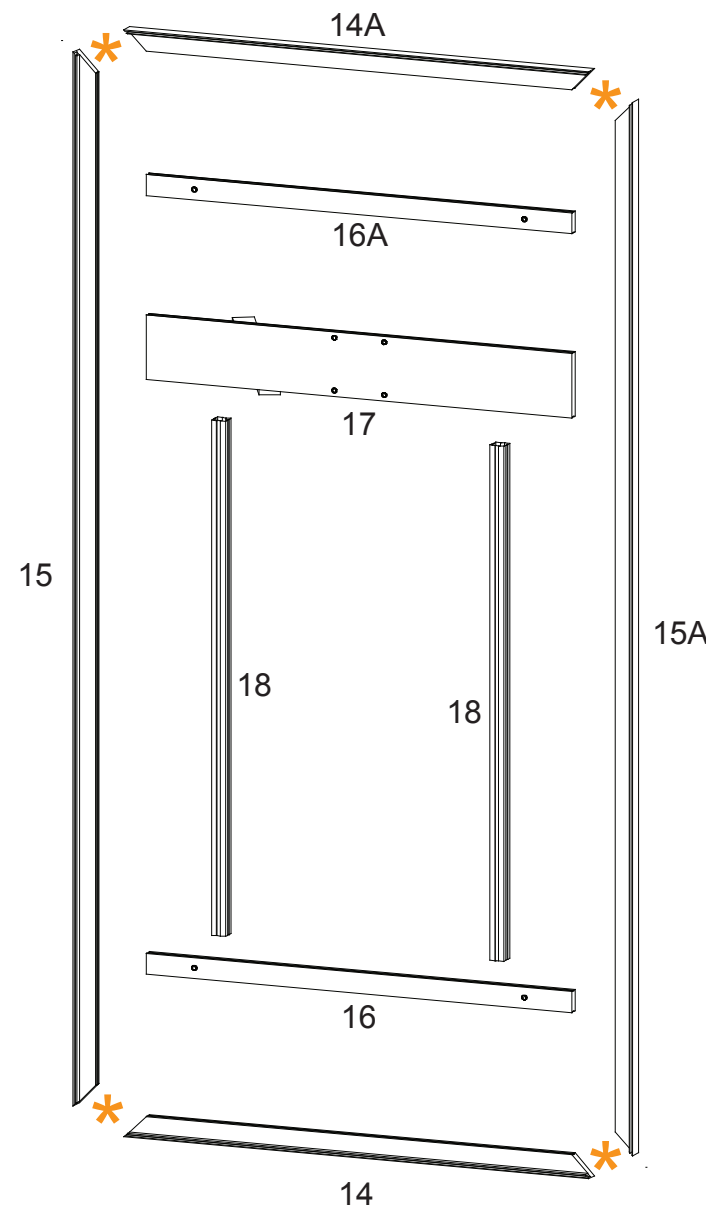
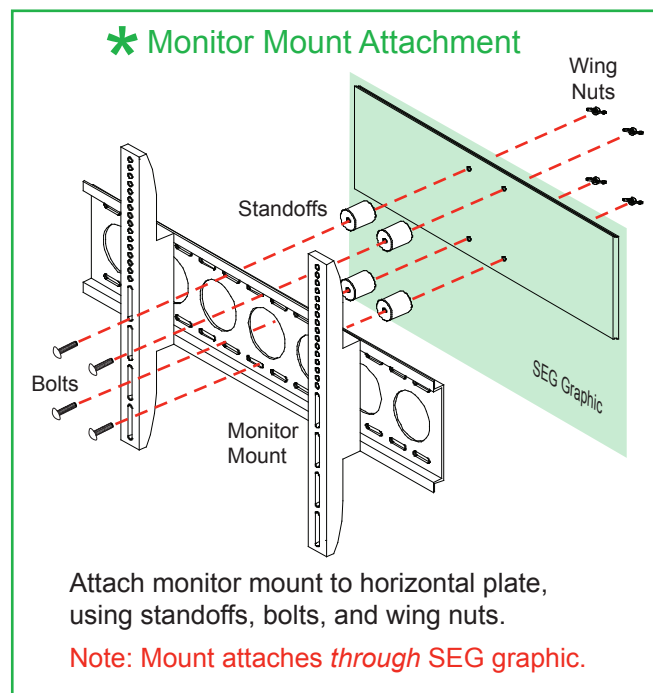
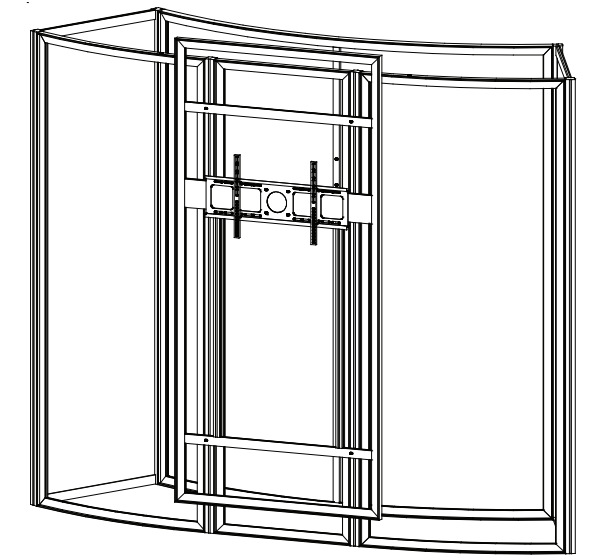
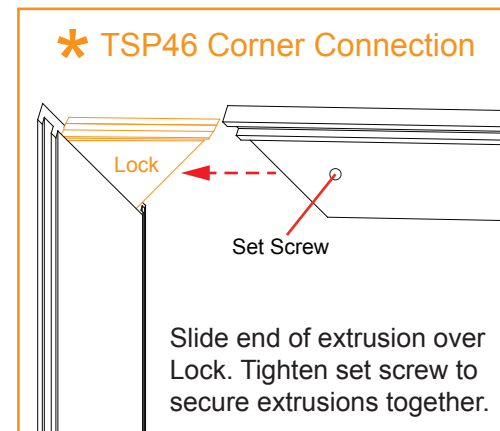



Steps:

- 1) Attach ceiling panels to top horizontal extrusions of closet, using V4 connectors & bolts.  
See **Ceiling Connection** detail.
- 2) Connect power cords to puck lights in ceiling panels.  
See **Puck Light Connection** detail. Use holes in ceiling panels for cord management.

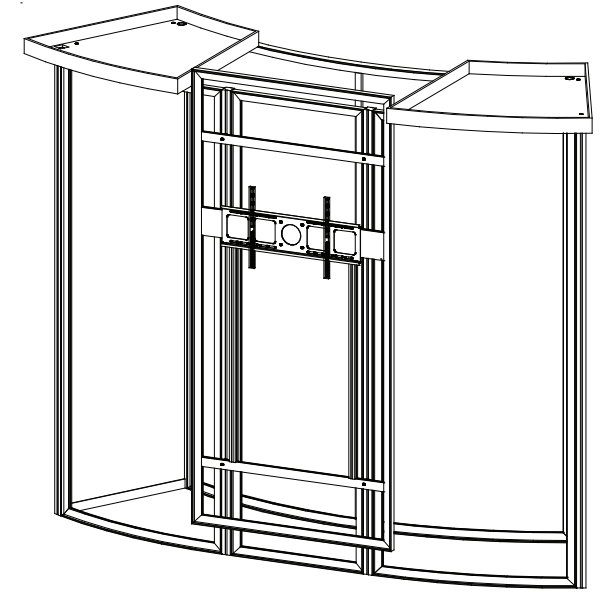
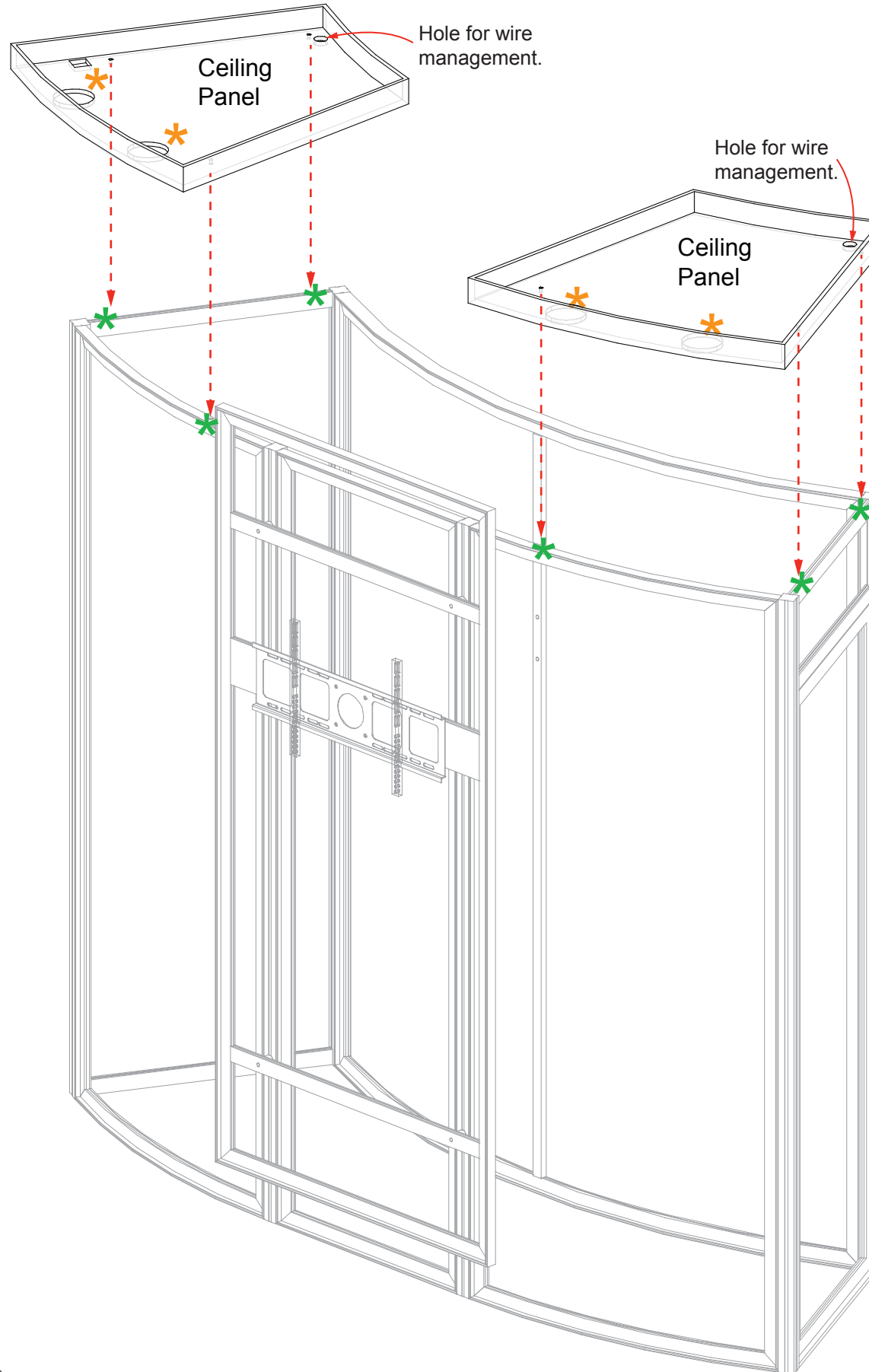

Completed Assembly

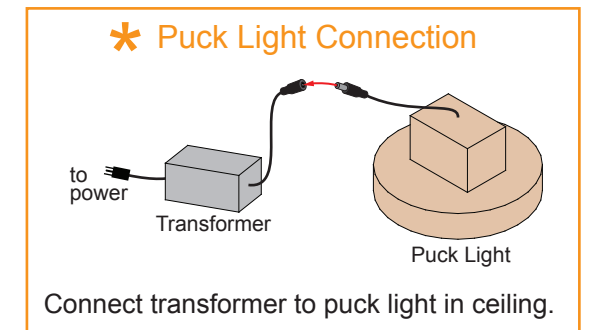
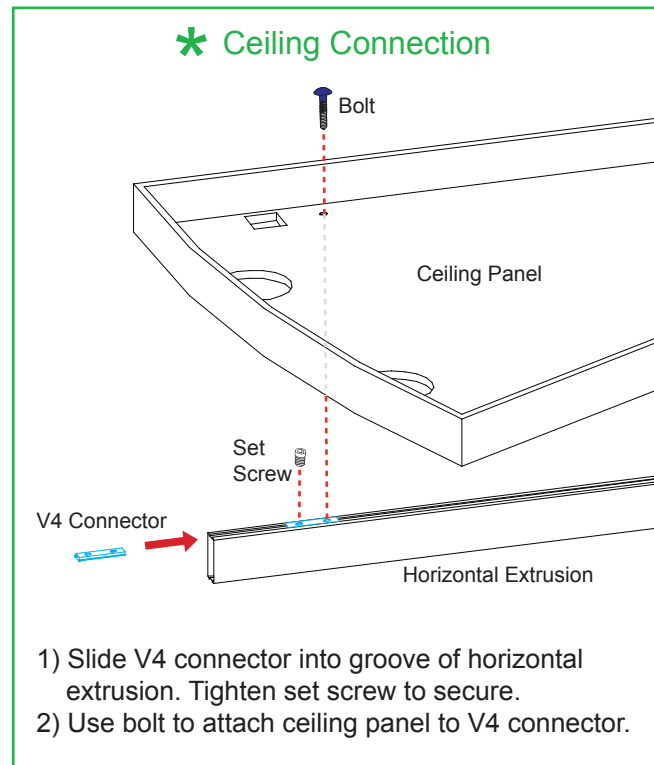

Item	Description
1	38" h 90° Connector
2	36.9738" w x 38" h Curved Panel w/ Door
3	38" h 90° Connector
4	19" w x 38" h Panel
5	38" h 90° Connector
6	44.13" w x 38" h Panel
7	38" h 90° Connector
8	19" w x 38" h Panel

Steps:

- 1) Assemble LT Panels in numerical order, as shown.
- 2) Attach shelf supports to Velcro on inside of counter base then place shelf on top of supports.
- 3) Attach counter top to assembled counter base. See Counter Top Lock detail.

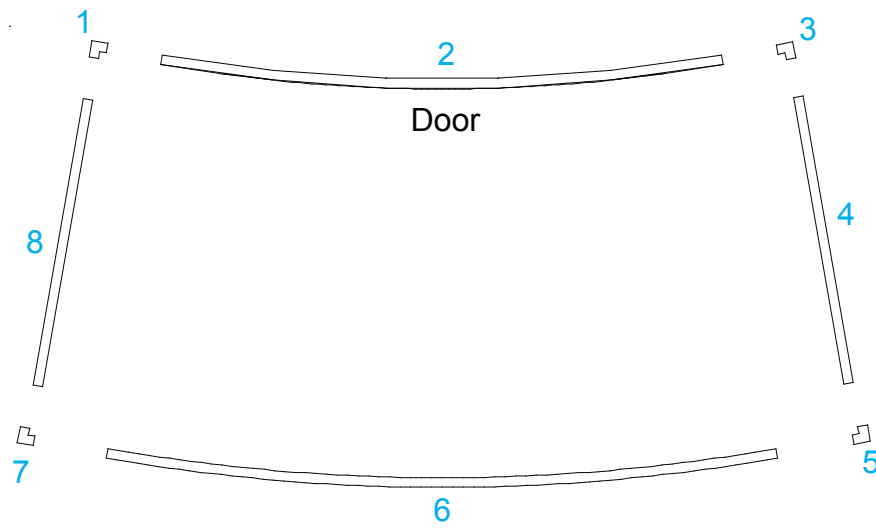

Top View of Counter Base

[5] [6] and [7] stay together when packing.

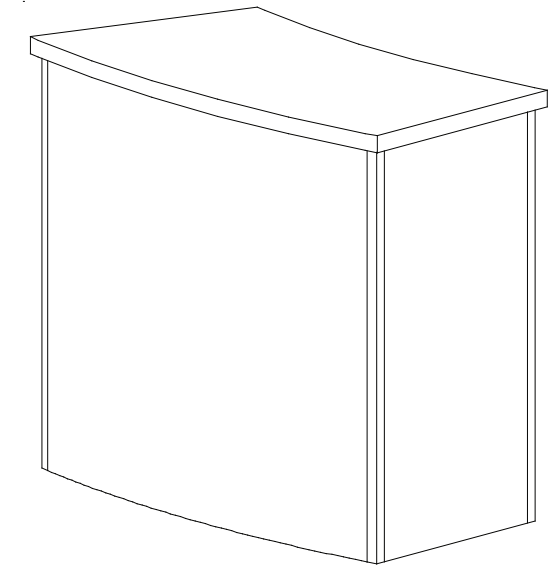
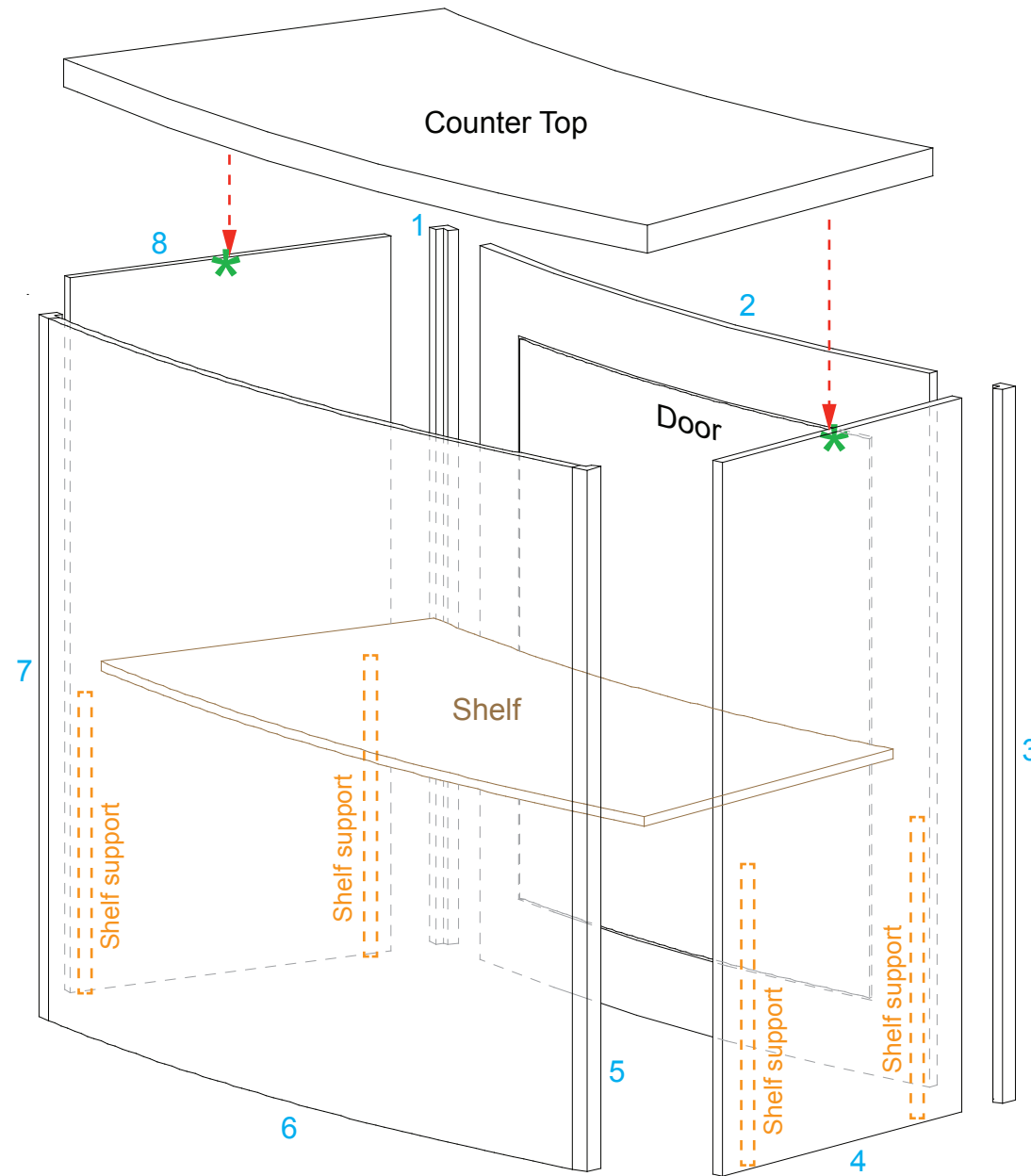

Completed Assembly

